

TOPOLOGICAL OPTIMIZATION OF A REAR FUSELAGE FRAME BASED ON SYMMETRICAL AND UNSYMMETRICAL LOAD CASES.

Cristiano T. de Mattos, José A. Hernandez

Instituto Tecnológico de Aeronáutica, Praça Mal. Eduardo Gomes 50, 12228-900, São José dos Campos, São Paulo, Brazil, hernandes@ita.br, <http://www.ita.br>

Keywords: Topology, bulkhead, optimization, frame, aircraft.

Abstract. The main subject of this work is to provide an optimal preliminary basic design for a machined frame located at the rear fuselage of an aircraft, using the topological optimization method. From several loading cases acting in the structure, only two of those were selected as the determining loading cases, both originated from the vertical empennage. The first corresponds to the aircraft vertical bending and the second to the aircraft torsion. This approach was necessary because the inclusion of all load cases in the optimization could not lead to a clear definition of the optimal design. The results obtained showed an optimal topology with strong resemblance to same purpose structures commonly found in practice.

1 INTRODUCTION

The use of structural topology optimization software has become a routine in the conceptual design phase of aircraft companies. In this context new designs of parts can be compared with common practice solutions adopted by industry. In this paper the design obtained from a topological optimization of a frame used to support the empennage is compared to similar existing solutions. It is found that the optimal topological design has great resemblance with the usual design. It is shown that among many existing loading cases only two of them are responsible for the optimal topology definition, namely fuselage bending and torsion induced by the empennage. The GENESIS (2005) software was used as the topological optimization tool since it has proved very good performance in many complex problems due to its efficient architecture based on sequential approximate optimization (SAO).

2 TOPOLOGICAL OPTIMIZATION

Topology optimization is often used by engineers to perform conceptual designs since it finds the optimal distribution of material in a given volume domain. The design starts with a block of material formed by a large number of finite elements, comprehending the volume domain, and the topology algorithm will “remove” the unnecessary elements. The topology optimization works by creating design variables associated to the density of each element, which are 0-1 discrete variables. However, to improve computational efficiency, a continuous formulation is used to solve the discrete problem such that design variables can assume values between 0 and 1, where 0 indicates the element has no stiffness and 1 that it has regular stiffness. The topology optimization problem with continuous variables seeks for the minimum flexibility (maximum global stiffness) having the following form according to the SIMP formulation (Bendsoe and Sigmund, 2003):

$$\begin{aligned} & \min_{\mathbf{u}, \rho_e} \mathbf{f}^T \mathbf{u} \\ & \text{subject to: } \left(\sum_{e=1}^N \rho_e^p \mathbf{K}_e \right) \mathbf{u} = \mathbf{f} \\ & \sum_{e=1}^N v_e \rho_e \leq V, \quad 0 < \rho_{\min} \leq \rho_e \leq 1, e = 1, \dots, N \end{aligned} \quad (1)$$

Here \mathbf{u} and \mathbf{f} are the nodal displacement and load vectors, respectively. The structure stiffness is assembled from penalized element stiffness matrices $\rho_e^p \mathbf{K}_e$. Here $p > 1$ is the penalty coefficient and ρ_e is called the element density of material since the volume of the structure is evaluated as $\int_{\Omega} \rho d\Omega$ and it interpolates the module of elasticity such that $E(\rho) = \rho E^0$, where E^0 is the real material module. The lower limit ρ_{\min} is used to assure the finite elements with small density will not be removed from the original mesh. V is a volume fraction of the original structural volume domain, v_e is the element volume and N refers to the number of finite elements been optimized.

GENESIS is the structural optimization software used to solve the problem stated in Eqs (1). It is based on sequential approximate optimization (SAO), which reduces drastically the number of complete finite element analyses and sensitivity analyses necessary to converge, such that the quantities depending on structural responses are explicitly approximated in terms

of the design variables (Leiva et al, 1999). One of its capabilities is to impose some fabrication requirements during optimization. In this paper we have used two advanced options, the first being the extrusion and the second symmetry, both giving some desired control of the optimization process. The extrusion tool creates a constraint to the optimizer to remove the entire thru thickness material of the elements at a certain direction. For example, for a thick plate modeled by solid elements we can impose that the optimization software remove material in a direction perpendicular to the plate mid-surface throughout its thickness where the material is less necessary. The symmetry tool forces the optimization software to remove material following a plane of symmetry established by the user.

The volume fraction used is the default value of 30.0 %. The design variables reduction is also limited to 30% in each iteration.

2.1 Finite Element Model

The part studied in this paper belongs to a T-tail type aircraft, where the vertical stabilizer spars are connected to the fuselage by fasteners onto machined frames. This type of attachment is widely used by many builders and its concept is very simple, although it implies that the load carried by the tail will concentrate at these attachment points located at the fuselage frames. These frames have the important function of spreading the load throughout the fuselage skin and stringers while having enough stiffness.

In our approach two types of loading will be used to size the rear fuselage frame. These loads are the critical vertical bending and the critical aircraft torsion produced by the empennage. Figure 1 illustrates the two cases where both will be applied as a positive and negative fuselage moment.

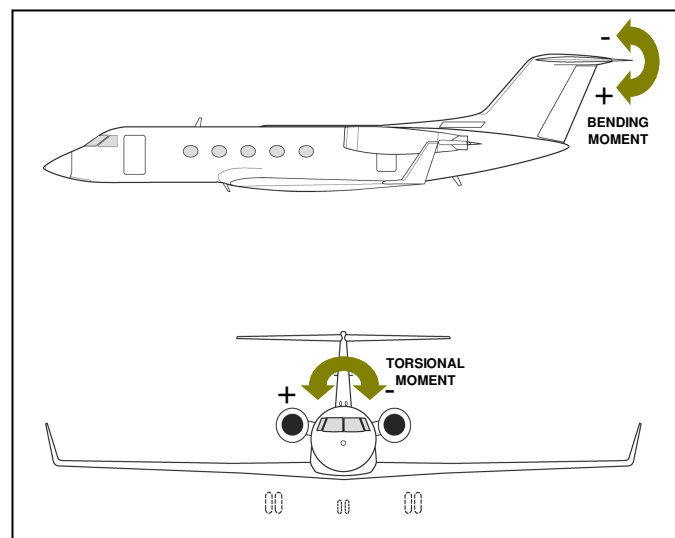

Figure 1 – Aircraft loading

The finite element model used in this analysis consists of a fuselage with typical construction (frames, skin and stringers) and a dummy vertical empennage on top to carry the loading. All parts are made of common aeronautical aluminum and the loads are carried by RBE3 elements. Figure 2 shows the finite element model used in the analysis, and can be seen that the fuselage model ends at a station far from the acting loading, so the model is

constrained at this station with little influence in the region where the frame to be optimized is located.

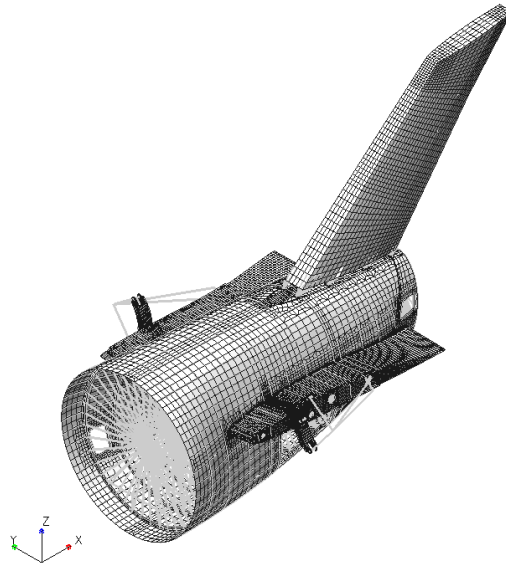

Figure 2 –Finite Element Model

There are four parallel frames which transfer loads from the empennage although the last frame (Fig. 3) carries a bigger share of load; therefore this frame was chosen to be the one optimized.

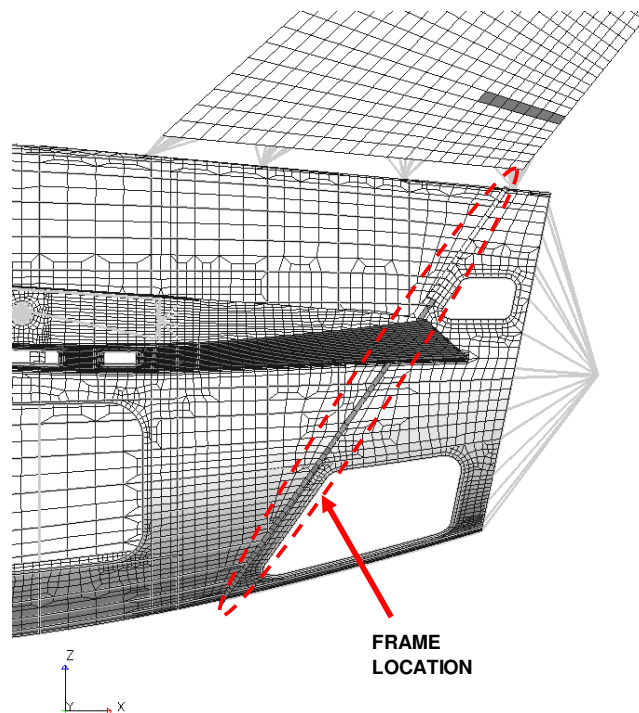

Figure 3 –Frame location

The basic idea is to create a solid plate and use the optimizer to “sculpt” the optimum design. With this purpose a finite element mesh was created covering the entire frame section by using solid elements, HEXA and TETRA elements. The constant thickness plate is discretized by two solid elements. Figure 4 shows the initial finite element domain (front and side view).

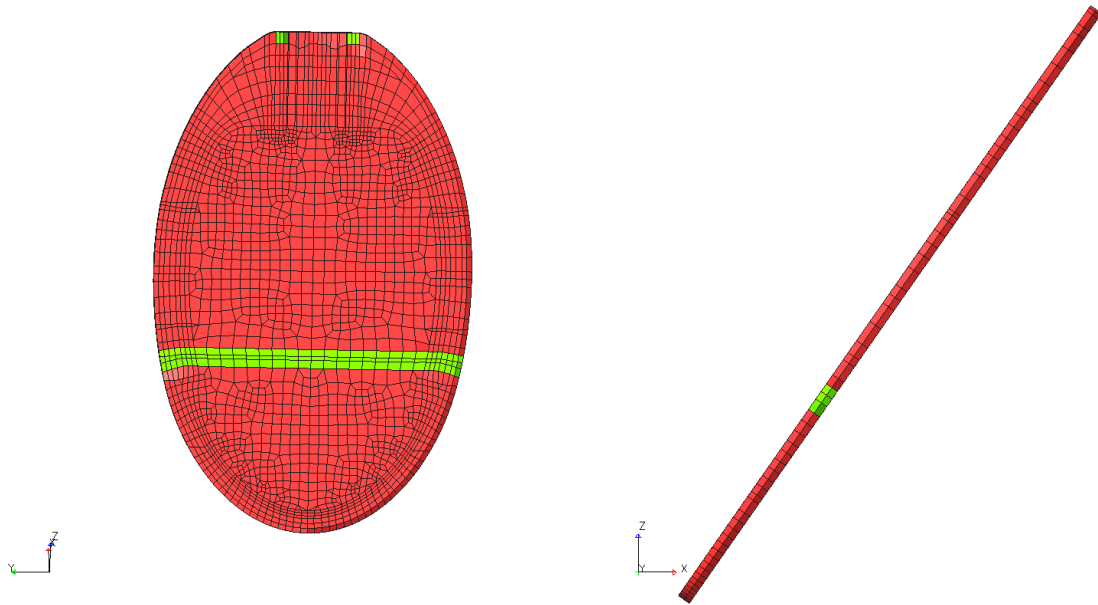

Figure 4 –Initial Finite Element domain, front and side view

As mentioned earlier, the GENESIS optimization will be executed considering extrusion and symmetry, in our case, the symmetry is imposed at plane XZ (see Fig. 4) and the extrusion direction is perpendicular to the frame section.

The green elements must remain unchanged during optimization; the ones located at the top of the frame section are responsible for the attachment of the empennage spar to the fuselage.

2.2 Results

Based on previous experience that the bending moment is the most important loading acting on the frame, the first run was made with only bending action. The frame was subjected to the extreme negative and positive bending moment loadings, where these opposing moments have different magnitudes which were obtained from the loading team. The optimal topology design is shown in Fig. 5 together with the optimization history. The result obtained was far from obvious and very different than expected. The result increased the inertia of the frame at its upper sides instead of at the top of the frame since this is the region where the loading is introduced. Therefore, a second optimization was tried with a different loading, which is the torsional loading. The loading is such that torsional extreme opposing moments of different magnitudes are introduced by the empennage. The optimal design and optimization history are shown in Fig. 6. The optimization created diagonal arms from the center of the frame to its sides. There is some residual unconnected material in the lower part of the frame, probably due to the premature ending of this more difficult load case, whose optimization history is not as smooth as in the previous case. It is interesting to observe that

both optimal designs are quite different, therefore these results were important to address the next assessment, to use both loading cases for the optimization of structure.

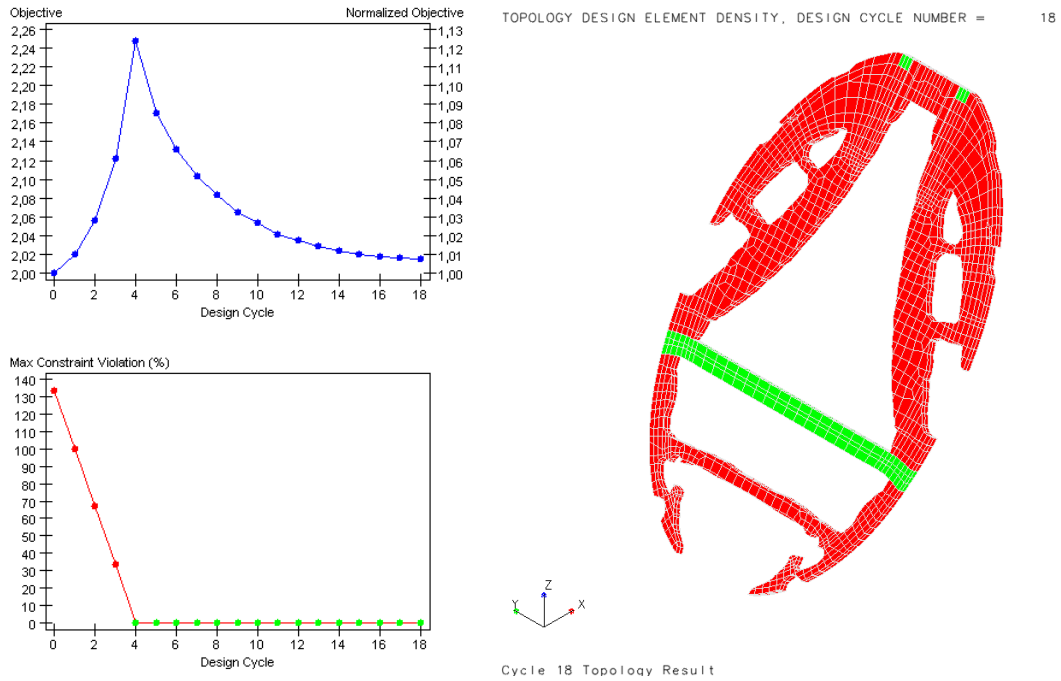

Figure 5 –Results for fuselage bending moment load cases

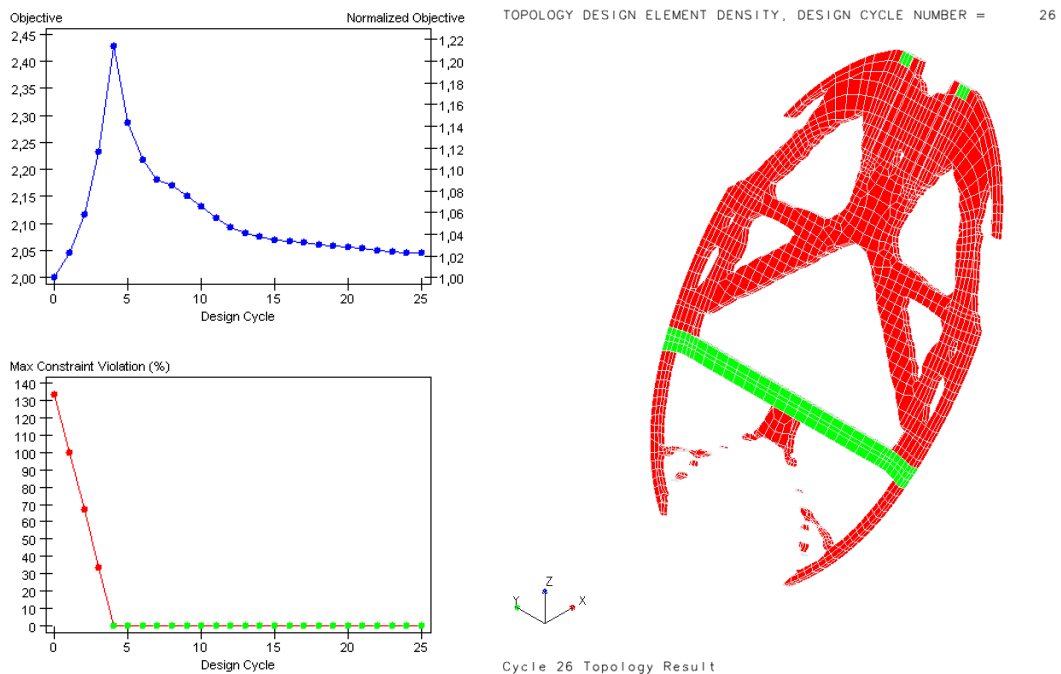

Figure 6 – Results for fuselage torsional moment load cases

Figure 7 shows the optimal design and history obtained for the frame when applying the bending and torsional load cases. It was believed that the bending loads would be the

determining ones, because of their prevalence of magnitude, however the torsional loading was dominant. This result of optimal topology has strong resemblance to same purpose structures commonly found in the industry and which unfortunately are not of public domain.

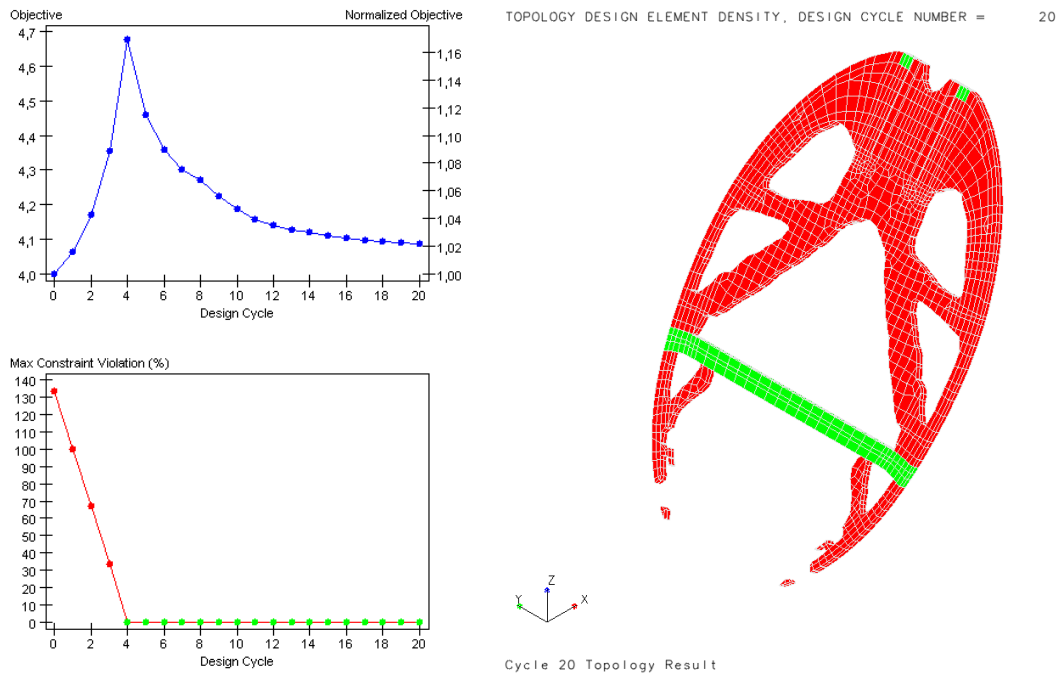

Figure 7 – Results for fuselage bending and torsional moment load cases

Acknowledgements

To the agency CAPES for the financial support and to Senior Eng. Ricardo Custódio Vidal, stress analysis manager at Embraer, for his inestimable contribution to this paper.

REFERENCES

Bendsoe, M.,P. Sigmund, O., *Topology optimization theory, methods and applications.* Springer- Verlag, 2nd ed. 2003.

GENESIS Design Manual, *Vanderplaats research & development Inc,* Version 8.0, 2005.

Leiva, J.P., Watson, B.C., Kosaka, I., *Modern structural optimization concepts applied to topology optimization, 40th AIAA/ASME/ASCE/AHS/ASC Structures, Structural Dynamics, and Materials Conference and Exhibit, St. Louis, MO, Vol. 3, pp.1589-1596.* 1999